

PCT-E1-30 Product Brief



Introduction

PCT series cards are PCI form factor Computer Telephony cards from SST. These are low-cost, high-density, highly integrated computer telephony cards. These are ideally suited for cost effective, high capacity Computer Telephony solutions (IVRS, call center applications, etc.). PCT-E1-30 is the first in the series of PCT cards. This supports one E1 interface with 30 simultaneous voice ports. If more than 30 ports are required, multiple cards can be inserted into the same system. The R2MF signalling protocol required for connecting to a switch is part of the firmware running on the card.

Features of the Architecture

All PCT series telephony cards use similar architecture. All are based on PCI bus. They support both 5V signaling and 3.3V signaling. All the cards have product IDs and Serial numbers embedded in them, which can be used by integrators to lock their software.

PCT cards use Programmable DSPs. The number of DSPs on-board is decided based on the current and future processing requirements. Having programmable DSPs on-board helps to add new features at a later date without modifying the hardware. This provides investment protection for the customers.

The Firmware running on the DSP is responsible for all the interface and protocol related functions. Firmware upgrade is as simple as installing the new software and restarting the application. So, the card need not be sent to the service center for Firmware upgrades.

Block Diagram

PCT-E1-30 has one E1 interface (supporting 30 simultaneous voice ports), two programmable 16 bit fixed point DSPs, a PCI interface IC and an EEPROM.

The E1 interface is compatible with ITU-T G.703 and G.704 specifications. There are two fixed point DSPs on-board and each DSP processing 15 voice ports. The DSPs are responsible for

- Transferring the speech data from the E1 interface to the host CPU memory and vice versa during record and play
- R2MF signalling protocol
- All the voice sample processing such as DTMF generation, DTMF Detection, Dial Pulse Detection etc.,

The PCI Interface IC is responsible for interfacing the DSP to the PCI bus. The PCI configuration details are stored in the EEPROM.

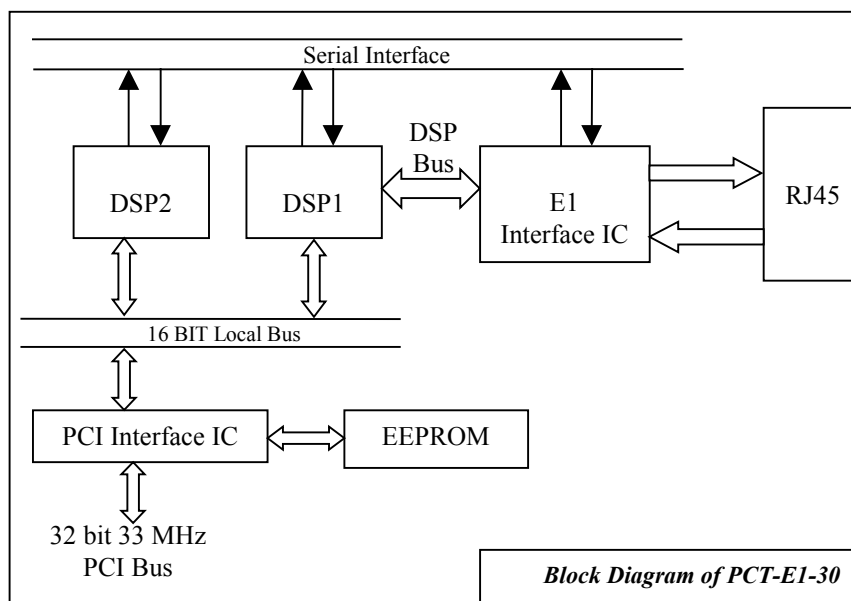

Features

- 30 voice channels per card. High channel density reduces the slot requirement on the PC.
- High integration reduces the cost. Contains E1 network interface, R2MFC signaling protocol and the voice processing.
- Currently supports WIN NT 4.0, WIN 2000 and WIN XP Operating Systems.
- Supports popular APIs for call processing (TAPI) and Media interfacing (WAVE API). Applications written using TAPI and WAVE API can be migrated to this card very easily.
- All 30 ports can be used to receive and originate calls, simultaneously, in any combinations.
- Supports recording of voice signals on all 30 ports. It supports, 8 kHz sampled A-law coding, 8 kHz sampled μ -law coding and 8 kHz sampled 16 bit linear wave formats.
- Supports playing of voice messages on all 30 ports. It supports, 8 kHz sampled A-law coding, 8 kHz sampled μ -law coding and 8 kHz sampled 16 bit linear wave formats.
- Supports DTMF detection, DTMF Generation and Dial Pulse Detection.
- Supports Caller ID.
- Supports FAX/Modem Answer Tone Detection

Technical Specification

- Number of Voice Ports: 30
- Network Interface: E1
- On-board Processing Power: 145 MIPS

Host Bus Requirement

- 33 MHz, PCI Ver 2.1 compliant Bus
- PCI Bus Master/slave card
- Universal 32-bit card (Can work in the predominantly existing 5V signalling and future 3.3V signalling environments).
- Card Size: Height: 4.2 inches, Length: 7.2 inches

OS Support

- Supports WIN NT 4.0, WIN 2000 and WIN XP

Application Development Support

- Supports TAPI 2.1 for call control
- Supports Wave API for media control

E1 Interface Specification

- HDB3 Line Coding
- Clock rate: 2.048 MHz, 50 ppm Accuracy
- ITU-T G.703 compliant physical layer
- ITU-T G.704 compliant Frame format
- Support for CRC4
- RJ45 connector
- Impedance: 120 Ohm
- Compliant Standards: ITU-T G.703, ITU-T G.704

Signaling Specification

- R2MFC signalling – Type I
- CLI supported

Speech Coding

- Sampling Rate: 8000 Hz
- PCM coding: 8 bit A-law, 8 bit μ -law and 16 bit Linear

DTMF Generation

- Digits Supported: 0 to 9, #, *, A, B, C, D (Other TAPI specified dialable characters are also supported)
- Frequency Accuracy: $\pm 0.4\%$ Maximum
- Dialing Rate: 10 digits/sec to 4 digits/sec (Selectable from the application)
- Pulse Duration: 20 msec to 200 msec (Selectable from the application)
- Transmit Level: -6 dBm
- Twist: 0 dB

DTMF Detection

- Digits Supported: 0 to 9, #, *, A, B, C, D
- Frequency Accuracy tolerance: 1.5% (verified through simulation)
- Pulse Duration: 50 msec minimum (verified through simulation)
- Detection Level: up to -30 dBm (verified through simulation)
- Acceptable Twist: ± 9 dB maximum (verified through simulation)

Dial Pulse Detection

- Supported

FAX/Modem Answer Tone Detection

- G3 FAX
- Data Modem

Power Supply Requirement

- +5VDC: 750 mA (Max)

Operating Environment

- Operating Temperature: 0°C to 50°C
- Storage Temperature: -10°C to +70°C

Other Related products from SST

- PCI based Analog Loop Start Interface board (PCT-AN-2/4)
- Host based Speaker independent Speech Recognition to run on this card
- Rhapsodia Text-to-Speech system for English

Contact us

India

Speech and Software Technologies (I) Pvt. Ltd.

(A TATA Enterprise)
3rd Floor, Ceebros Arcade,
3rd Cross Road, Kasturibai Nagar,
Adyar, Chennai – 600 020. India
Tel: +91-44-2442 5370/71
Fax: +91-44-2442 5369
Email: sales@sstil.com

USA & International

Speech and Software Technologies (I) Pvt. Ltd.

(A TATA Enterprise)
PO Box 6722
Edison, NJ 08818-6722
USA
Tel: 718-948-5118
Email: raj@sstil.com

Website: www.sstil.com